

4-see the drawing F10061
"Dreamline Barrel kit"

Art. No	Description
20140	Barrel kit Dreamline .177
20141	Barrel kit Dreamline .22
20149	Barrelkit Dreamline 22 600mm
20142	Barrel kit Dreamline .25
20143	Barrel kit Dreamline .30

Position	Description	Art. No.	Position	Description	Art. No.
1	Pressure gauge 25mm Plastic 1/8"	11505	40	Countersunk Screw M3x6	2504
2	Dust Cover	19544	41	Grub Screw M2,5x2,5	12035
3	Tube end pressure gauge	20080	42	Safety pivot Bullpup	20056
3.1	Plastic washer 2mm 1/8"	5005	42.1	Safety lever 32,5mm	19860
3.2	O-ring 24x2 NBR 70	19484	42.2	Safety knob	11200
3.3	O-ring 23,0x2,5 NBR 70	19485	42.3	Grub screw M3x8	19742
3.4	O-ring 4x1.5 NBR70	19109	43	Cup point grub screw M3x3	2562
3.5	Countersunk screw M4x8 Torx	11511	44	Cylindrical pin 2h6x20	11502
4	Barrel cpl., see drawing F10061-Dreamline Barrel kit		45	Pellet probe Dreamline .177	20060
5	Tube 34x360 (.177, .22)		45	Pellet probe Dreamline .22	20061
5	Tube 34x475 (.25, .30)	19831	45	Pellet probe Dreamline .25	20062
6	Regulator Airtube adjustable. - See drawing F10056	20199	45	Pellet probe Dreamline .30	20063
7	O-ring 23x2.5 NBR70	19485	46	Hammer V7	19039
8	Valve holder Dreamline, until ser.no. 194000	20037	47	Hammer weight cal. .177, until ser. No. 194000	19215
9	Spring 0,5x4x20, until ser.no. 194000	19850	47	Hammer weight addition cal. .177, until ser. No. 194000	18041
10C	Valve pin Dreamline Complete, until ser.no. 194000	20135	47	Hammer Weight cal. .22, .25, .30, until ser. No. 194000	17003
10	Valve Pin Dreamline, until ser.no. 194000, included in complete valve pin	20036	47	Hammer weight, after serial No. 194000, cal. .177, .22, .25	19215
11	Holder Valve seal, included in complete valve pin	2041			
12	Gasket SHP, included in complete valve pin		47	Hammer weight cal. .30, after serial no. 194000	17003
12	Valve gasket 7.4x3x5x2.9 Impact, from ser.no. 0101759, included in complete valve pin 20153C-1		48	Hammer spring V2	11500
13	O-ring 1,5 x 1,0 NBR 70, also included in complete valve pin	2528	49	Hammer spring adjuster (only on Classic model)	11541
14C	Valve seat SHP Complete, until serial no. 0101759	19060	50	Cylindrical pin 3h6x20	11510
14C	Valve seat Complete, after serial no. 0101759	2024C	51	Carrier Dreamline	20058
14C	Valve seat Cal.30 Complete 10J-12FT	19217	52	Grub screw M3x4	16092
15	O-ring 6x1 NBR 90, also included in valve seal complete	19060	53	Cylindrical pin 2.5m6x6	19026
15	O-ring 8x1 NBR 90, also included in valve seal complete	2024C	54	Linkage Crown	19935
16	O-ring 23x2.5 NBR70	19485	55	Cylindrical pin 2h6x10	19213
17	Grub screw M6x6	19846	56	Socket head cap screw MC6S M3X18	11060
18	Grub screw M8x6	19955	57	Side lever handle handle B2-WC-IM	19611
19	Cylindrical pin 2h6x6	19601	58	Magnet 5x4mm	20055
20	X-ring 3,63x2,62 NBR 70	19762	59	Side lever Dreamline	20064
21	Pressure gauge 23mm	19772	60	Screw M3 (special)	19034
22	Main block Dreamline, until serial no. 190310 use art.no. 20020 R	20126R	61	Grub screw M4x6 flat, until ser. No. 190310	2637
23	Power adjuster, outer, until serial no. 190310 use art.no. 20034	20125	62	Spring 0,5x2,5x6,1 ... until ser. No. 190310	11501
24	Power adjuster Crown, until serial no. 190310 use art.no. 19915	20123	63	Steel ball 3mm, until ser. No. 190310	4066
25	Countersunk screw M4x14	16104	64	N/A	
26	O-ring 11.1x1.6 NBR90	19956	65	Countersunk screw M4x6, after ser. no. 190310	5208
27	O-ring 5,5 x 2 NBR 70	19953	66	Grub screw M3x3, after ser. no. 190310	2562
28	Power adjuster inner, Crown, until serial no. 190310 use art.no. 19922	20124	67	Steel ball 3mm, after ser. No. 190310	4066
29	N/A	N/A	68	Spring 0,5x2,5x6,1 ... after ser. No. 190310	11501
30	Trigger sear V7,8,12	19177	69	Grub screw M3x3, after ser. no. 190310	2562
31	Spring 0,5x2,5x6,1	11501	70	Cover Valve Pin long, HP, after ser.no. 194000	20152
32	Steel ball 3,175mm v1.2.3.4.5	11527	70	Cover Valve pin long, 10J, 12Ft, after ser.no. 194000	20175
33	Spring 0,32x3,2x14,4	11504	71	O-ring 13,95x2,62 NBR 70, after ser.no. 194000	12045
34	Trigger Wheel	11525	72	O-ring 2,5x1,5 NBR90, after ser.no. 194000	5111
35	Grub screw M3x8	19742	73	Springseat, after ser.no. 194000	19038
35.1	Grub screw M3x10	11508	74	Spring 0,6x4x60, after ser.no. 194000	20180
36	Adjuster screw 2:st stage, soft	11062	75	Valvepin Dreamline long complete, after ser.no. 194000 until ser.no. 0101759	20153C
37	Triggercatch Dreamline, standard	20033	75	Valvepin Dreamline long complete, after ser.no. 0101759	20153C-1
38	Trigger pin	19809	76	Barrel support Dreamline	20162
39	Adjustable Trigger blade	19136	77	O-ring 20x1 NBR 70	20159

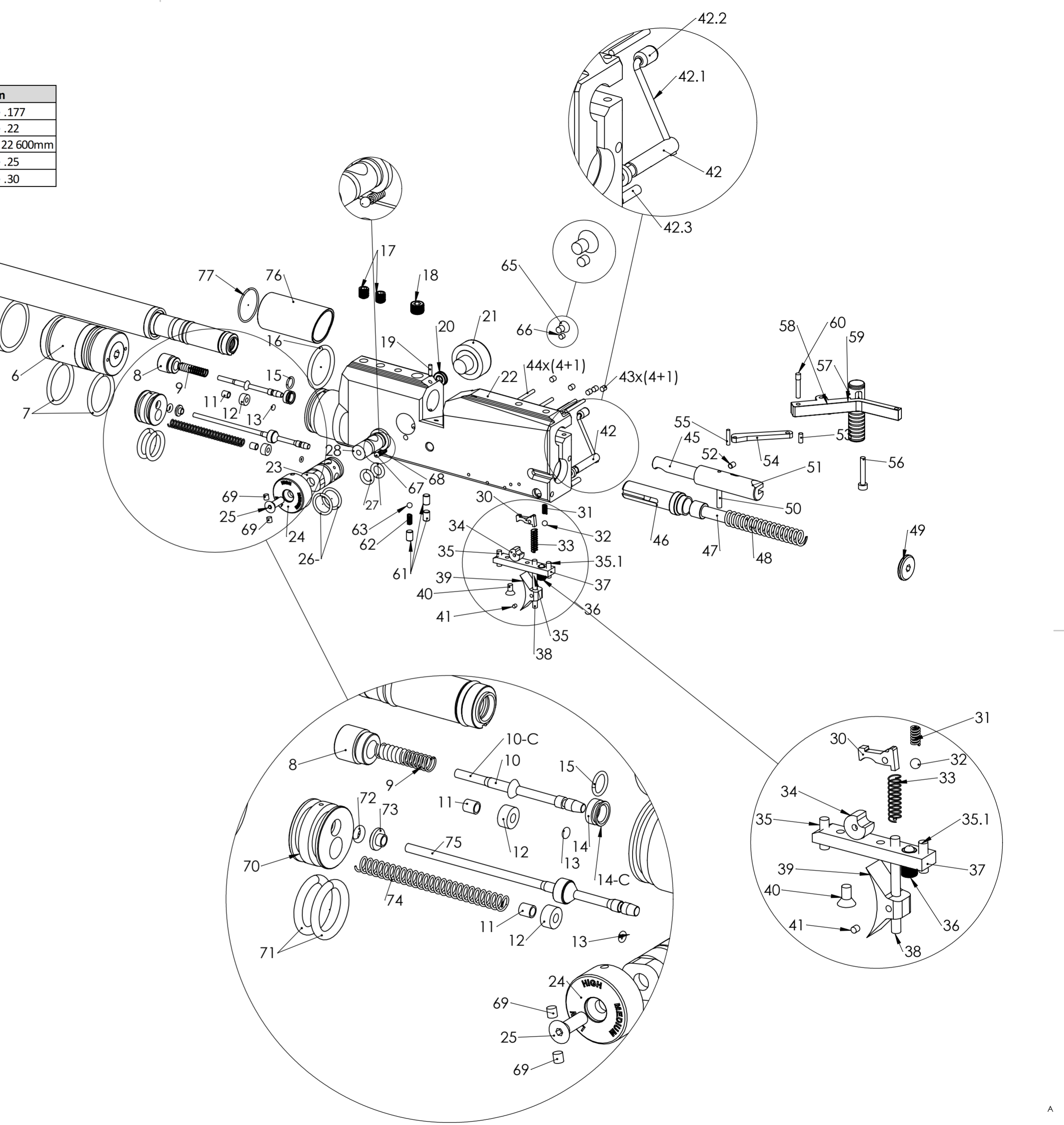

TITLE: Dreamline Basic

MATERIAL:				FXairguns		DWG NO. F10057-3	ART NO. ART NO.	A2
DRAWN	NAME	DATE	CHANGE DATE	REVISION	A	SCALE:1:2	SHEET 1 OF 2	

